



**Vestil Manufacturing Company**  
 2999 North Wayne Street, P.O. Box 507, Angola, IN 46703  
 Telephone: (260) 665-7586 -or- Toll Free (800) 348-0868  
 Fax: (260) 665-1339  
[www.vestil.com](http://www.vestil.com)    [info@vestil.com](mailto:info@vestil.com)

## A-LIFT Manual Winch Lift Trucks



**A-LIFT-S**



**A-LIFT-R**



**A-LIFT-CB**



**A-LIFT-HTL**

### Receiving Instructions

After delivery, remove the packaging from the product. Inspect the product closely to determine whether it sustained damage during transport. If damage is discovered, record a complete description of it on the bill of lading. If the product is undamaged, discard the packaging.

**NOTE:** The end-user is solely responsible for confirming that product design, use, and maintenance comply with laws, regulations, codes, and mandatory standards applied where the product is used.

### Technical Service & Replacement Parts

For answers to questions not addressed in these instructions and to order replacement parts, labels, and accessories, call our Technical Service and Parts Department at (260) 665-7586. The Department can also be contacted online at <https://www.vestil.com/page-parts-request.php>.



### Electronic Copies of Instruction Manuals

Additional copies of this instruction manual may be downloaded from <https://www.vestil.com/page-manuals.php>.

<b>TABLE OF CONTENTS</b>		<b>PAGE</b>
Signal Words.....		2
Safety Instructions.....		2
National Standards.....		2
Specifications.....		3
FIG 1A: Parts Diagram.....		4
Parts List for Fig. 1A.....		5
Assembling the A-LIFT.....		5, 6, 7, 8
Raising and Lowering the Deck.....		8
Using the A-LIFT.....		9, 10
Using the Deck Platform.....		10
Transporting the A-LIFT.....		11
A-LIFT-HTL-27-300-44 Water Heater/Tank Lifter.....		11
[A-LIFT-HTL-27-300-44] Exploded View of Tank Lifting Carriage.....		11
Using the Water Tank Lifter.....		12
Record of Satisfactory Condition.....		13
Inspection & Maintenance.....		13
Labeling Diagram.....		14
Limited Warranty.....		15

## SIGNAL WORDS

SIGNAL WORDS appear in this manual to draw the reader's attention to important safety-related messages. The following are signal words used in this manual and their definitions.

 <b>DANGER</b>	Identifies a hazardous situation which, if not avoided, <b>WILL</b> result in <b>DEATH</b> or <b>SERIOUS INJURY</b> . Use of this signal word is limited to the most extreme situations.
 <b>WARNING</b>	Identifies a hazardous situation which, if not avoided, <b>COULD</b> result in <b>DEATH</b> or <b>SERIOUS INJURY</b> .
 <b>CAUTION</b>	Indicates a hazardous situation which, if not avoided, <b>COULD</b> result in <b>MINOR</b> or <b>MODERATE</b> injury.
<b>NOTICE</b>	Identifies practices likely to result in product/property damage, such as operation that might damage the product.

## SAFETY INSTRUCTIONS

Vestil strives to identify foreseeable hazards associated with the use of its products, but no manual can address every conceivable risk. Minimize the likelihood of injury by observing the hazards identified below and by inspecting and maintaining the product as instructed in [INSPECTIONS & MAINTNENANCE](#) on p. 20.

### **WARNING**

Risks of serious personal injuries or death. Always apply material handling techniques learned during training and use the product properly.

- **Read and understand the entire manual before assembling, using or servicing the product.**
- Inspect the lifter as directed in the [INSPECTIONS & MAINTENANCE](#) instructions on [p. 13](#). DO NOT use the lifter unless it is in satisfactory condition. See [RECORD OF SATISFACTORY CONDITION](#) on [p. 13](#).
- ALWAYS inspect the area where the lifter will be used before using it.
- Regardless of whether the lifter is loaded or unloaded, DO NOT stand or travel under the deck.
- Instruct others to stay clear of the device and the supported load during operation.
- Avoid contact with moving parts. In particular, avoid contact with the cable, deck, wheels & rollers.
- DO NOT allow people to ride on the lifter.
- Failure to properly position a load on the deck might result in injury:
  1. DO NOT exceed the maximum rated load (capacity). The rated load appears on label 287 as shown in [LABELING DIAGRAM](#) on [p. 14](#). Also see applicable [SPECIFICATIONS](#) on [p. 3](#).
  2. Center & evenly distribute loads. DO NOT handle off-center loads or loads that cannot be centered.
  3. Start & stop gradually to avoid upsetting the load on the deck. Strap loads to the deck if they might roll or slide.
  4. NEVER tilt the lifter while carrying a load. All wheels and casters must maintain contact with the ground when a load is on the deck.
- Watch the deck while raising and lowering the carriage. The carriage/deck should rise smoothly and evenly from side-to-side. Watch for binding or jerky movement and listen for unusual noises. Tag the unit "Out of order" and do not use it if you observe anything abnormal.
- Only use this lifter on even, level ground. DO NOT transport loads on inclines or stairs.
- Enlist a coworker to help you lift, load, and unload the unit whenever necessary.
- DO NOT perform maintenance on this product UNLESS it is unloaded and the carriage is lowered. If the unit requires repairs, ONLY install manufacturer-approved replacement parts.
- Before leaving the unit unattended, lower the carriage/deck to the ground and remove the load.
- DO NOT use the lifter UNLESS all labels are in place and readable. See [LABELING DIAGRAM](#) on [p. 14](#).
- DO NOT modify this product in any way. Modifying the lifter automatically voids the limited warranty and might make it unsafe to use.

## NATIONAL STANDARDS

This product is referred to as a manually propelled high lift truck. The Industrial Truck Standards Development Foundation (ITSDF) publishes national standard ANSI/ITSDF B56.10 (the "Standard") on its website ([www.itsdf.org](http://www.itsdf.org)). The standard is freely downloadable at <http://www.itsdf.org/cue/b56-standards.html>. Before putting the unit into service, acquire a copy of the Standard and apply all recommendations in Part II: For the User. If instructions provided in this manual conflict with instructions in the Standard, then you should apply the instructions in the Standard. Vestil encourages you to immediately contact [TECHNICAL SERVICE](#) to report any differences between instructions in this manual and the Standard.

# SPECIFICATIONS

Documents that provide specifications for A-LIFT model lifters are available online to anyone who visits Vestil's website. Specifications include dimensions, net weight, and capacity information. To access the appropriate specifications document, navigate to the appropriate webpage: A-LIFT-HTL-27-300-44 at <https://www.vestil.com/product.php?FID=1495> or all other A-LIFT models at <https://www.vestil.com/product.php?FID=270>. Click the *Product Specifications Table* tab. Scroll the page to the entry for the model you purchased, and click the button in the *PDF* column that looks like a pencil inside a box. A PDF file will open. This file is the specifications document. Print a copy of the document and keep it with your copy of this manual. The following is an exemplar specifications document for model A-LIFT-R.

## HAND WINCH LIFT TRUCK - A-LIFT-R

\*\*\*ANY ADDITIONS, DELETIONS, OR OMISSIONS MUST BE CORRECTED ON THIS DRAWING AS THIS DRAWING WILL BE CONSIDERED ALL INCLUSIVE\*\*\*

ALL GRAPHICS PROVIDED ARE FOR REFERENCE ONLY. IF CERTAIN DIMENSIONS ARE CRITICAL PLEASE VERIFY THOSE DIMENSIONS WITH YOUR SALESPERSON

### STANDARD FEATURES

MODEL NUMBER IS: A-LIFT-R  
 DURABLE STEEL AND ALUMINUM CONSTRUCTION  
 CAPACITY IS: 500 LBS.  
 OVERALL WIDTH IS: 23 15/16"  
 OVERALL LENGTH IS: 35 1/8"  
 OVERALL HEIGHT IS: 68 3/4"  
 HAND CRANK WINCH WITH REVERSIBLE HANDLE  
 FORKS CAN BE INVERTED TO PROVIDE TWO DIFFERENT HEIGHTS  
 LOWERED HEIGHT FORKS DOWN IS: 3 1/2"  
 LOWERED HEIGHT FORKS UP IS: 23 1/2"  
 RAISED HEIGHT FORKS DOWN IS: 47"  
 RAISED HEIGHT FORKS UP IS: 67"  
 TWO Ø8" NON-MARKING REAR WHEELS  
 TWO Ø2" FRONT SWIVEL CASTERS  
 APPROXIMATE WEIGHT IS 126 LBS

### SPECIAL FEATURES

NONE

FOR INTERNAL USE ONLY PROJECT SIGN OFF	
SALES	
ENG.	
FAB.	
POWER	

I, THE UNDERSIGNED, AGREE THAT THE PRODUCT AS REPRESENTED SATISFIES DESIGN AND DIMENSION REQUIREMENTS. I ALSO ACKNOWLEDGE MY DUTY TO CONFIRM PRODUCT AND INSTALLATION COMPLIANCE WITH ALL APPLICABLE FEDERAL, STATE AND LOCAL REGULATIONS AND STANDARDS.

**UNITS REQUIRING APPROVAL DRAWINGS OR MODIFIED ARE NON-RETURNABLE**

[ ] As drawn [ ] As marked

Signed: \_\_\_\_\_ Date: \_\_\_\_\_

Printed Name: \_\_\_\_\_

LEAD TIME WILL START UPON RECEIPT OF SIGNED APPROVAL DRAWING

DISTRIBUTOR'S NAME:		P.O.#
VESTIL MANUFACTURING		X
DRAWN BY: T.MOORE		W.O.#
DATE: 10/21/18		X
REFERENCE: X	SCALE: 1:18	FILE NAME:
QUOTED LEAD TIME: X	QUOTE #	21-007-074
	X	

# FIG. 1A: Parts diagram

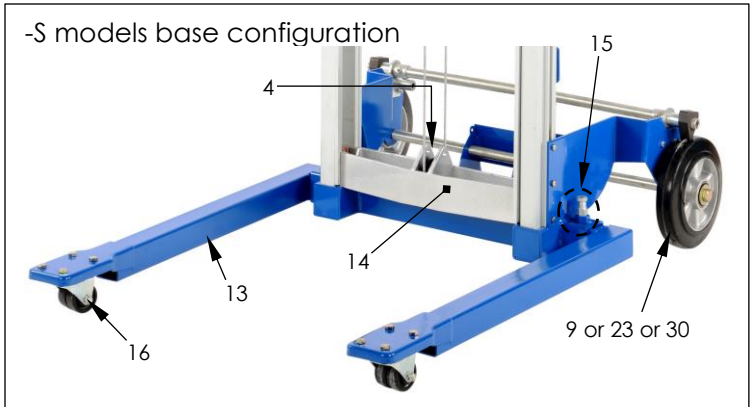
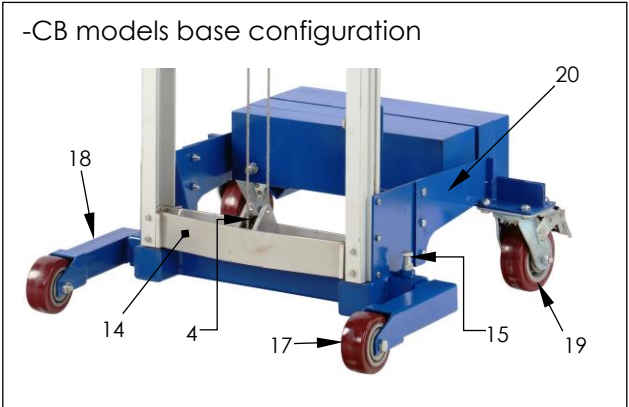

## Parts List for Fig. 1A

“Standard Units” refers to A-Lift-R, -S, & -CB models; “HP Units” means A-Lift-R-HP, -S-HP, and -CB-HP models; “EHP Units” indicates A-Lift-S-EHP and -CB-EHP models.

Item	Description	Part No.	Quantity	Item	Description	Part No.	Quantity
1	Operator Handle	A-Lift-1	1	18	Adjustable Leg (-CB counterweight base models)	A-Lift-CB-18	2
2	Loading Wheels	A-Lift-2	2	19	5 inch Swivel Caster with brake	A-Lift-CB-19	2
3	Upper casting	A-Lift-3	1	20	Counterweight Base	A-Lift-CB-20	1
3a	Inner frame pulley (large)	A-Lift-3a	1	21	Caster	A-Lift-R-21	2
4	Large Pulley	A-Lift-4	2	22	Legs - Standard base (R models)	A-Lift-R-22	2
4a	Large cable anchor bolt & nut	A-Lift-4a	3	23	Solid Rubber Wheel	A-Lift-23	2
5	Cable (Standard Units)	A-Lift-5	1	24	Brake (optional)	A-Lift-24	1
5a	Cable (EHP Units)	A-Lift-EHP-5	1	25	Fork Lock Pin	A-Lift-25	4
6	Telescoping Inner Mast Frame (only HP & EHP Units)	A-Lift-6	1	26	Winch Mounting Bracket	A-Lift-26	1
7	Mast Frame	A-Lift-7	1	27	Winch	A-Lift-27	1
8	Decal Plate	A-Lift-8	1	27a	Winch Handle	A-Lift-27a	1
9	10 in. Pneumatic wheel (optional)	A-Lift-9	2	27-SPG	Winch Spring	A-Lift-27-SPG	1
10a	Carrriage rollers 30x41 (EHP models)	A-Lift-R-10a	4	28	Not Available	N/A	N/A
10b	Carrriage rollers 33x55	A-Lift-R-10b	4	29	Deck (optional)	A-Lift-Deck	1
11	Fork Mounting Tube	A-Lift-11	2	30	[-S models with 4-point casters] 4in. caster – option A 5in. caster – option B	A-Lift-29A A-Lift-29B	
12	Fork	A-Lift-12	2	31-32	Not Available	N/A	N/A
13	Adjustable Leg (Straddle base)	A-Lift-S-13	2	33	Pivoting carriage latch	A-Lift-33	1
14	Lower casting	A-Lift-14	1	34	Small pulley	A-Lift-34	1
15	Leg Lock Pin	A-Lift-CB-15	2	34a	Small pulley bolt & nut	A-Lift-34a	1
16	Caster	A-Lift-S-16	2	35	Operator handle bracket	A-Lift-35	2
17	4 inch Fixed Wheel	A-Lift-CB-17	2	36	Load wheel bracket	A-Lift-36	2

## ASSEMBLING THE A-LIFT

Vestil ships winch lifts to its customers in a mostly assembled form. The minimal assembly that is required differs by model, so follow the directions that correspond to your lifter.

If you purchased an **A-LIFT-R** or **A-LIFT-S**, you will receive 3 pieces:

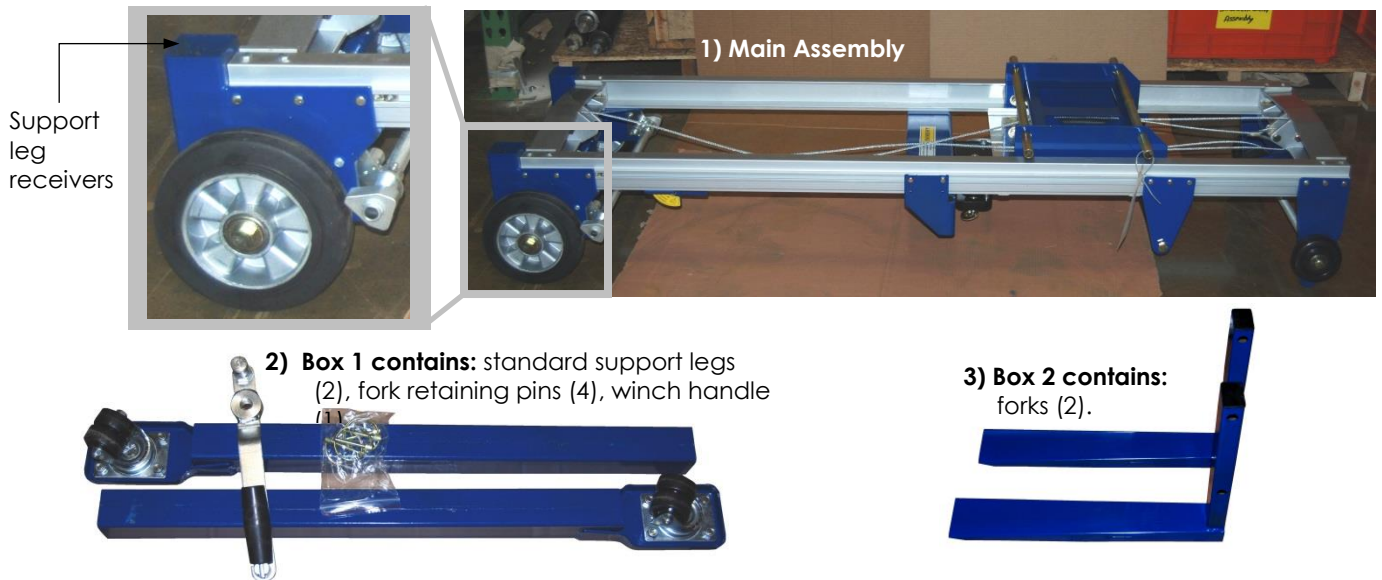

**Step 1:** Connect the support legs to the main assembly by following instructions (a) through (e).

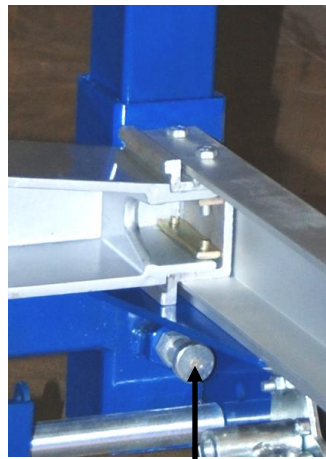

Spring-loaded retaining peg

- (a) Insert a support leg into each of the receivers in the main assembly.
- (b) Pull the retaining pegs to allow the legs to drop to the bottoms of the openings.
- (c) Release the pegs. The pegs should seat into holes in the legs. You might have to wiggle the leg to get the peg to drop.
- (d) Pull up on each support leg to verify that the pegs have seated properly. The legs should not be able to slide out of the opening. If a leg comes out of its receiver, the corresponding peg did not engage properly. Repeat (a) through (d).

**Step 2:** Lift the assembly to the upright position (photo a). Then, lock the brakes (photo b) and fasten the winch handle to the winch body (photos c – f).



a

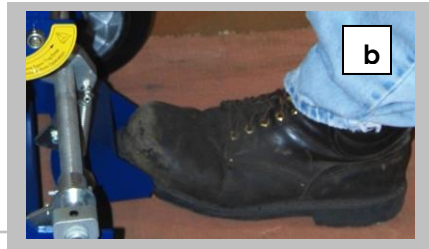

b

Engage the brakes by pressing down on the brake pedal

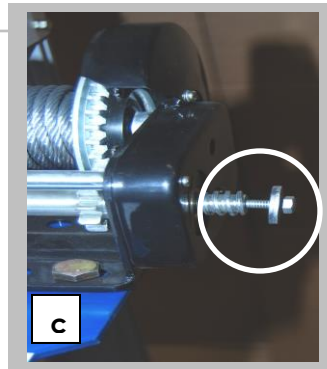

c

Remove the handle retaining bolt and washer (circled)

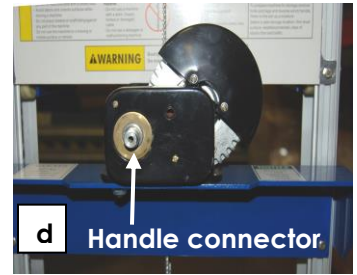

d Handle connector

Winch body with bolt and washer removed



e

Slide the handle onto the handle connector

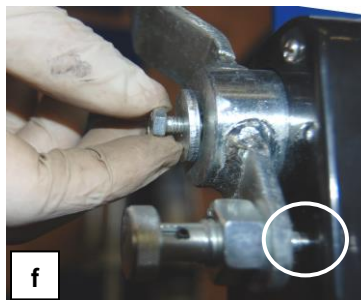

f

Set the handle locking pin (circled) to lock the handle, and then fasten the handle to the handle connector with the bolt and washer that you removed in step (c).

**NOTE:** Secure the washer against the bolt head with a nut BEFORE fastening the bolt to the connector. This will prevent the bolt from loosening when the handle is rotated counterclockwise to lower the forks.



**Step 3:** Attach the forks to the carriage.

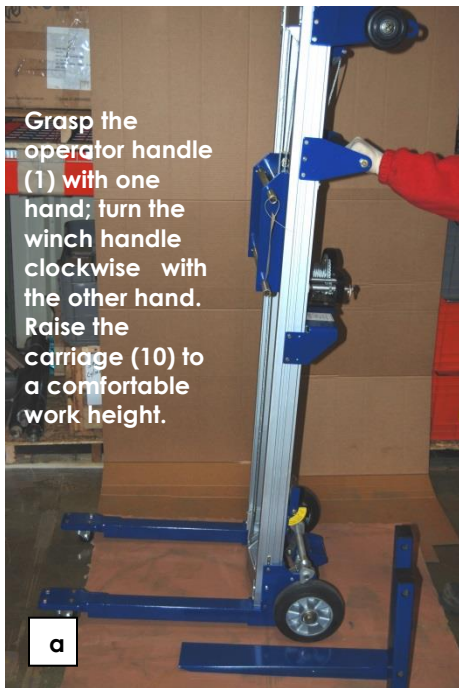

Grasp the operator handle (1) with one hand; turn the winch handle clockwise with the other hand. Raise the carriage (10) to a comfortable work height.

**b.** Align the holes in the forks with the carriage cross- bars (11); then push the forks until they contact the carriage. Note: It may be necessary to tap the forks into place with a rubber mallet. NOTE: Forks shown installed right side up, but they can also be installed upside down (.

**c.** Slide fork retaining pins (25) through the holes in each of the carriage crossbars.

**d.** Lock the pins into place by swinging the ring portion of each pin downward

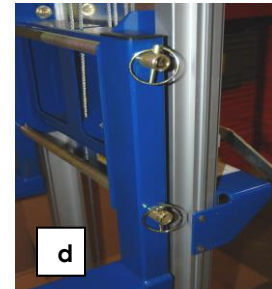

**Step 4:** Turn the winch handle counterclockwise to lower the forks. Lower the forks until they are a few inches above the support legs (22), and then push the lifter to the desired location.

**Counterbalanced lifters (A-Lift-CB):**

**Step 1:** Attach the 5 inch swivel casters (19) to the counterweight base weldment (20).

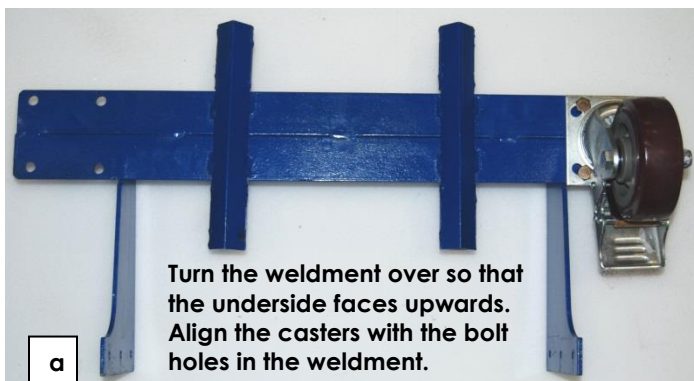

Turn the weldment over so that the underside faces upwards. Align the casters with the bolt holes in the weldment.



Lock nut

Bolt

Drop bolts through each of the holes. Secure each bolt with a lock nut. Tighten all of the connections with a pair of wrenches.

**Step 2:** Attach the weldment to the main assembly.

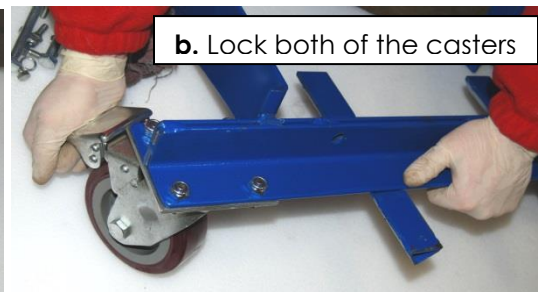
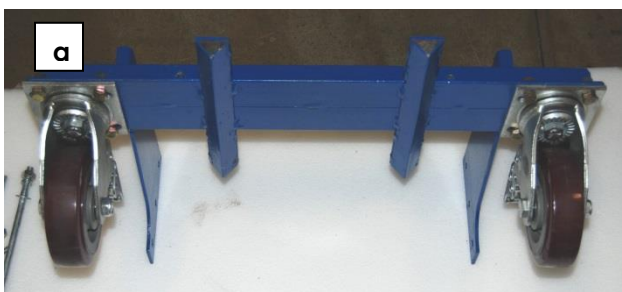

**c.** Lay the main assembly on the ground winch side up.

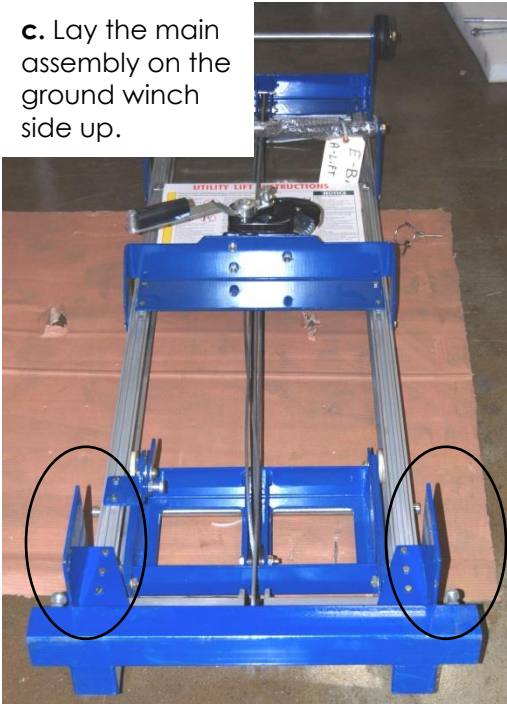

**d.** Align the bolt holes in the weldment with the holes present in the weldment brackets (circled in photos c & d).

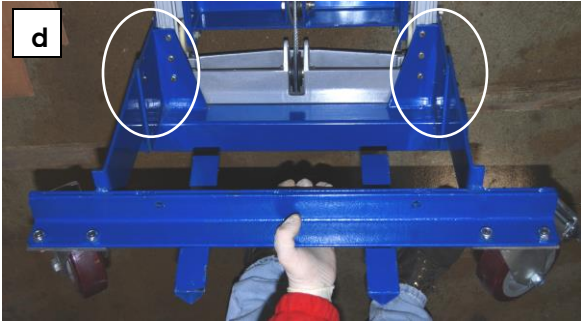

**e.** Bolt the weldment to the main assembly, and then secure the bolts with nuts.

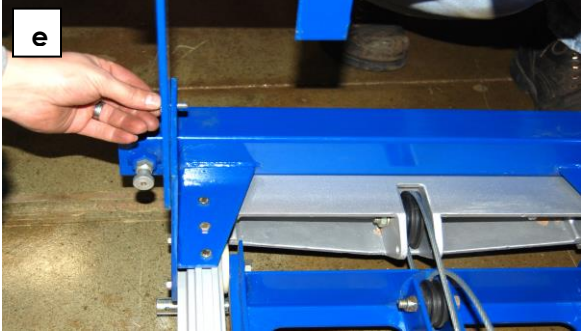

**f.** Set the four counterweights on the weldment; then insert the counterweight retaining bolts



**g.** Fasten the bolts in place using a flat washer, followed by a lock washer and then a nut.



**Step 3:** Install and position the forks by following R & S model fork installation steps 3 & 4 on p. 7.

## RAISING AND LOWERING THE DECK

To raise and lower the deck, the lifter is equipped with a manual winch.

**Winch:** To raise the platform, pull the handle locking pin up and rotate it slightly to fix it in the UP position. Then, rotate the winch handle clockwise. The platform rises ~1 inch with each rotation. To lower the platform, rotate the handle counterclockwise.



The diagram shows a manual winch mounted on a blue metal frame. A red arrow points to the 'Handle locking pin' at the top of the handle. Another red arrow points to the 'Winch mounting bracket' where the winch is attached to the frame. A red arrow at the bottom indicates the 'Clockwise' direction of rotation, and another red arrow on the right indicates the 'Counterclockwise' direction.



## USING THE A-LIFT

This product is a “manually-propelled high lift industrial truck” according to the national standard ANSI/ITSDF B56.10 (“B56.10”). Acquire a copy of the most recent revision of B56.10, which is freely downloadable at no cost from the ITSDF website ([www.itsdf.org](http://www.itsdf.org)). Review the operation recommendations. Instructions in this manual are meant to **supplement** the recommendations of B56.10.

ONLY use this device after completing the training program outlined in B56.10.

- Develop safe working habits and an awareness of hazardous conditions occurring or present during operation of the lifter. Do NOT use the lifter on stairs. Only use the lifter on even, level concrete/asphalt surfaces.
- Inspect the lifter as recommended in the [INSPECTION & MAINTENANCE](#) section of this manual on [page 13](#). Use the lifter only if it is in satisfactory condition.
- Inspect the area where the lifter will be used **before each use** to identify unusual operating conditions. Implement additional safety precautions as conditions require. Conditions might include:
  1. Irregularities in the floor/surface;
  2. Debris or other obstructions on the floor/surface;
  3. Unsound surfaces, i.e. surfaces that cannot support your weight plus the weight of the lifter and a full capacity load.
- Perform the following **function tests before each use**:
  1. Raise and lower the deck and confirm normal operating condition of the winch, pulleys, carriage and all associated mechanisms.
  2. Test the casters/wheels: wheels should roll smoothly, should not be severely worn, and should be rigidly fastened to the frame of the lifter.
  3. Confirm that the caster locks/brakes function normally. See Step 4 on p.10.

**Step 1 (-S and -CB Models):** Adjust the legs to provide the desired wheel base. Set the brake (-S models) or lock the casters (-CB models). Remove the forks and lock the carriage using the pivoting carriage latch (photo a). Slowly tilt the lifter backwards until the loading wheels contact the ground. Pull the leg adjustment peg (photo b) and slide the leg in the desired direction. Reset the peg in the first or second adjustment setting (photo c) as the job requires.

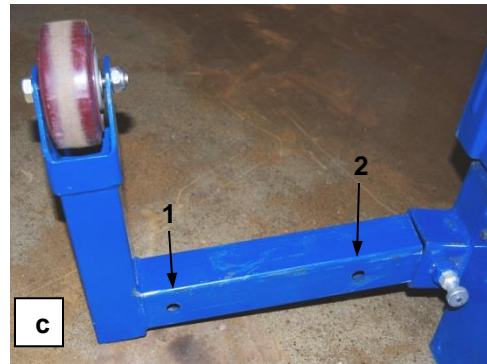
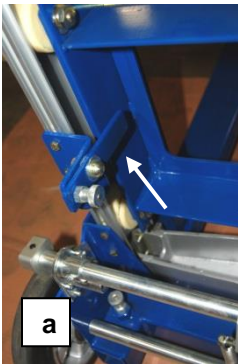

**Step 2:** Grasp the handle with both hands. Walk behind the lifter and keep your feet away from the wheels.



**a.** Grasp the operator handle at each end. This will provide the greatest degree of steering control.

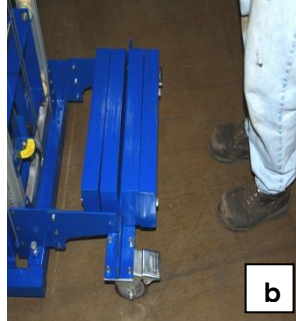

**b.** Walk behind the lifter and keep your feet clear of the casters.

**⚠ WARNING** DO NOT place one foot on the counterweights and propel the lifter with the other foot. Doing so will make the lifter more difficult to control.

**Step 3:** Move the lifter to a position near the intended load and lock both of the locking casters. If necessary, enlist a coworker to help you lift, load, and unload the A-lift;



Raise the forks to a comfortable height by turning winch handle clockwise.



Set the load on the forks. The load must rest against the back of the forks.



Lower the forks by turning the winch handle counter-clockwise until the load is a few inches above the adjustable leg. Rotate the handle clockwise 1/4 turn to set the winch brake.

**Step 4:** Move the load to the desired location.



Push down to apply castor brake

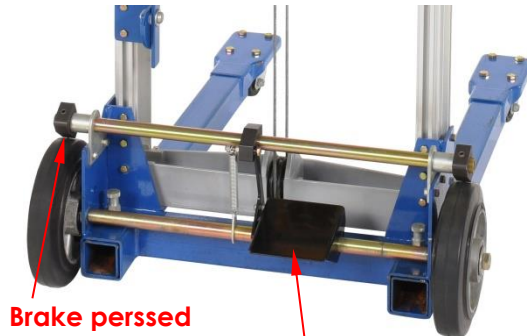

Brake pressed against wheel

Brake pedal: push forward to apply brakes.

Once at the unloading site:

- Lock the casters (press down on castor locks) or set the brakes;
- Unlock the winch handle and turn it clockwise until the load is positioned at a comfortable height;
- Lock the winch handle;
- Remove the load.
- Lower the forks until they are a few inches above the legs.

**Step 5:** Return the lifter to its storage location. Engage the brakes, fold the winch handle, fully lower the forks, and set the handle latch pin to lock the winch handle. Store the lifter in a dry location that is protected from weather.

## USING THE DECK PLATFORM

The forks must be attached to the carriage right-side up, as shown below and in the [Parts Diagram](#) on [p. 4](#).



Slide the curved lip of the deck under the lower carriage cross bar.



Set the lip on top of the lower carriage cross bar; let the deck rest on top of the forks.

When finished using the deck, remove it and store it in a dry location.

## TRANSPORTING THE A-LIFT

Before loading the A-lift into a transport vehicle, perform the following steps to minimize the chance of damaging the lifter:

1. Remove the forks and store the forks and fork retaining pins.
2. Lower the carriage completely.
3. Rotate the pivoting carriage latch as shown by photos a & b to the right.

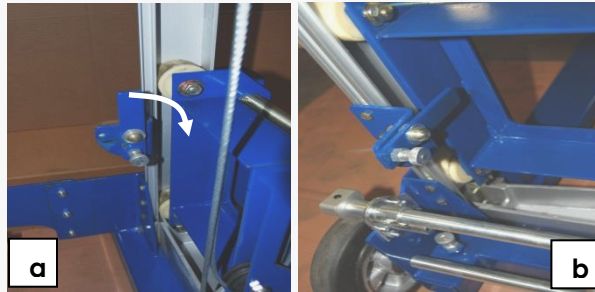

## A-LIFT-HTL-27-300-44 WATER HEATER/TANK LIFTER

This model is specially adapted to lift water heater tanks. The lifting adaptation includes a ratchet strap and tank support attached to a movable carriage. The ratchet strap securely holds a selected water tank against the carriage. Lifting and lowering functions are performed by a manually-operated winch. Rotate the winch handle clockwise to raise the carriage and the tank supported by the carriage. Turn the handle counterclockwise to lower the carriage.

### EXPLODED VIEW OF TANK LIFTING CARRIAGE 21-006-153

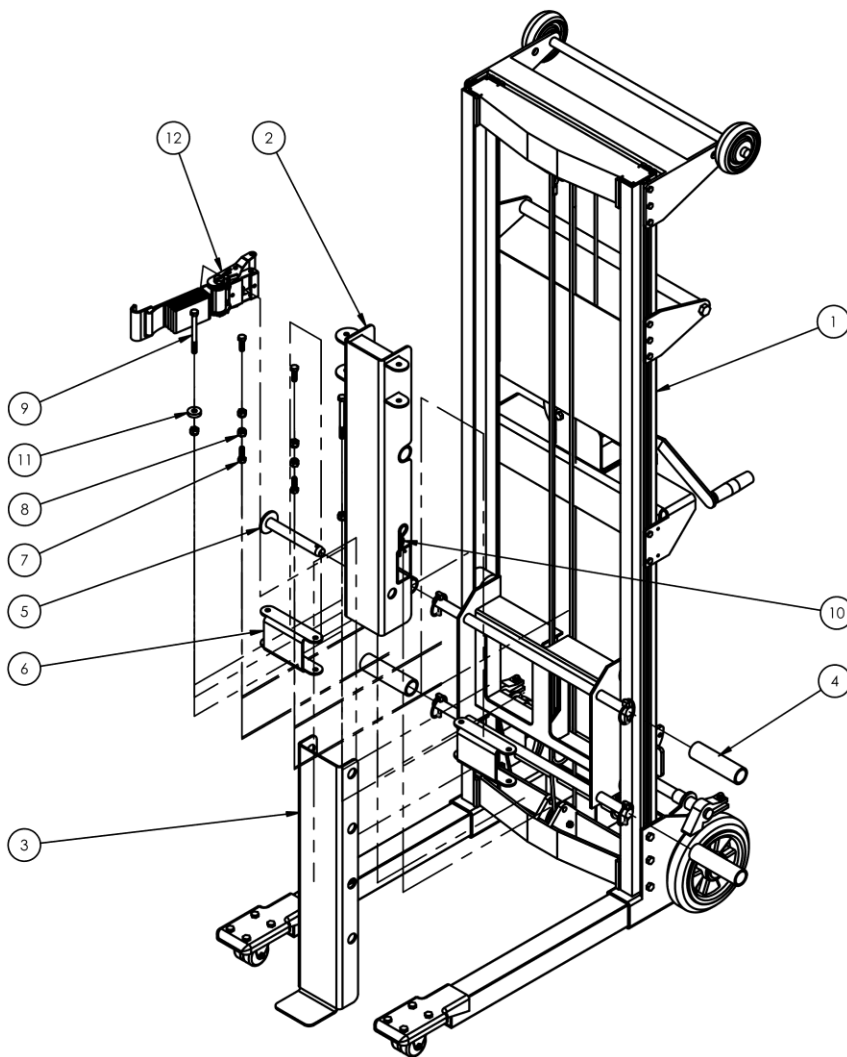

ITEM	PART NO.	DESCRIPTION	QTY.
1	21-001-074	FINAL ASSEMBLY W/O SHIPPING	1
2	21-514-167	WELDMENT, FRAME SUB-ASSMBLY	1
3	21-014-220	FRAME, CHANNEL, FORMED ("TANK SUPPORT" WITH "TANK PLATE")	1
4	21-014-219	FRAME, PIPE SPACER	4
5	21-612-001	WELDMENT, PIN	1
6	21-012-005	HINGE, CHANNEL, FORMED	2
7	11055	HEX BOLT, GRADE A, ZINC PLATED, 5/16-18 X 1	4
8	37021	NYLON INSERT LOCK NUT, GRADE 2, ZINC FINISH, 5/16"-18	6
9	11067	HHCS #2 Z PLATED, GRADE A, Ø 5/16 - 18 x 3.5 LG	2
10	45286	#11 HITCH PIN CLIP, Ø1/8" X 2 5/8 LG	1
11	20-027-005	ROLLER GUIDE	1
12	16-145-018	2" x 36" STRAP WITH RATCHET	1

## USING THE WATER TANK LIFTER

1. Move the lifter to the tank selected for transport. Position the lifter next to the tank. Slide the tank plate under the tank until the side of the tank firmly contacts the tank support.
2. The lifter includes an orange ratchet strap equipped with a steel J-hook on one end. If the strap is not already installed in the ratchet mechanism, feed the free end of the strap into the strap slot. **NOTE:** Feed the strap from inside the ratchet mechanism, i.e. between the ratchet brackets.
3. Wrap the ratchet strap around the tank and connect the hook to the hook bolt.
4. If the strap must be extended to wrap around the tank, pull the release lever up (toward the end of the handle) and hold it. While holding the release lever up, pivot the ratchet handle approximately 180 degrees to the OPEN position. Let go of the release lever. Pull the strap to unwind it from the spool. The ratchet handle is shown in the OPEN position.
5. Pull the release lever up and pivot the handle back towards the fixed end of the mechanism. Tighten the strap against the tank by moving the handle back-and-forth.
6. Turn the winch handle clockwise and lift the tank just a few inches above the ground.
7. Grasp the operator handle and pull it toward you. Push the truck to the destination. When loaded, the truck should only be used on even, level ground. Do not traverse sloped ground unless you are able to easily control the truck. Always remain upslope of the truck if you must traverse sloped ground.
8. Unload the tank from the truck by lowering the tank to the ground (turn winch handle counterclockwise). Then, turn the handle clockwise 1/4 turn to set the brake. Release strap tension by applying the procedure described in step 4 (above).

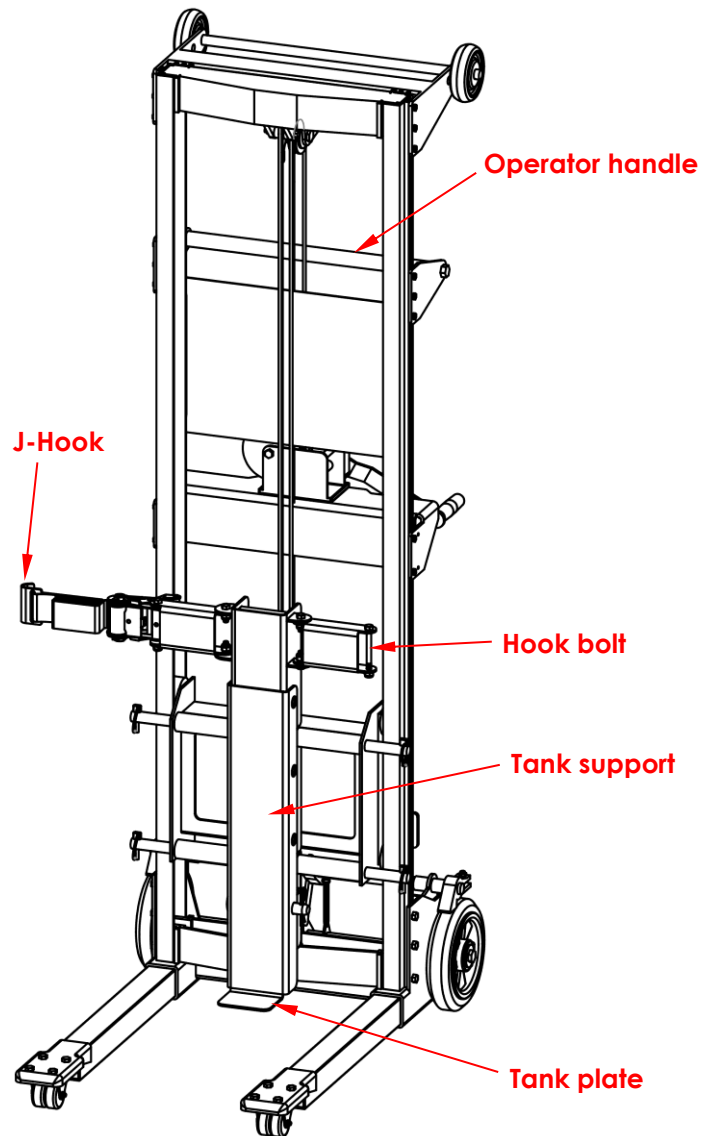
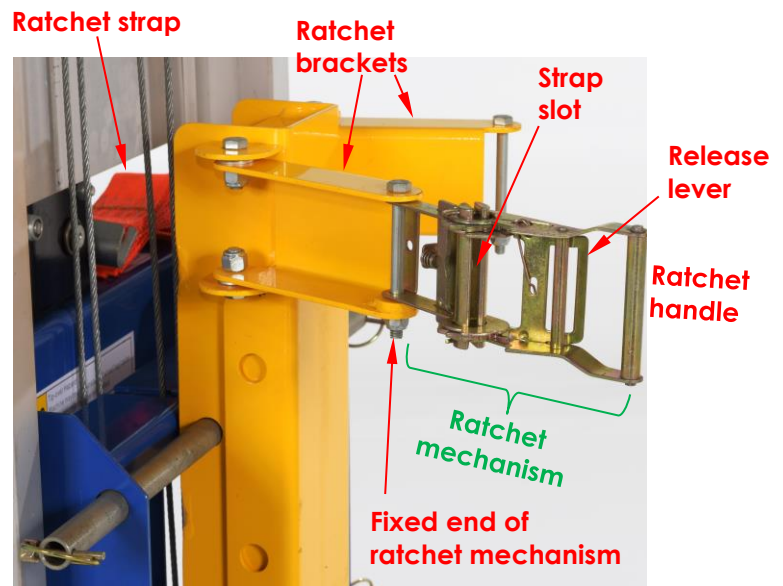

## RECORD OF SATISFACTORY CONDITION (THE “RECORD”)

Record the condition of the product before putting it into service. Thoroughly photograph the unit from multiple angles so that all operating mechanisms are clearly visible. Take close range photographs of the labeling applied to the lifter. Raise and lower the deck. Describe the operation of the winch. Describe sounds heard as the deck rises and descends. How much effort is required to turn the winch? Apply the brake and/or caster lock (as equipped). Photograph the brakes and/or caster locks. Try to move the lifter while the brakes/caster locks are applied and describe the strength of resistance to movement. Collect all photographs and writings in a single file. Give the file a name that clearly identifies it. This file is a record of the unit in satisfactory condition. Compare the findings of all inspections to the record to determine whether the lifter is in satisfactory condition. Purely cosmetic changes, like damaged paint/powder coat are not changes from satisfactory condition. However, touch-up paint to be applied to all affected areas as soon as damage occurs.

## INSPECTION & MAINTENANCE

Regular inspections and maintenance are necessary to keep the device in satisfactory condition. Compare the results of each inspection to the [RECORD](#) to determine whether the unit is satisfactory condition or requires repairs or replacement parts. If you are uncertain whether a part requires repair or replacement, contact [TECHNICAL SERVICE](#) for assistance.

- Periodically lubricate moving parts.
- Keep the product clean and dry.
- Only use manufacturer-approved replacement parts.

### INSPECTION

Before each use, inspect the lifter for any the following conditions:

- a) Significant wear/fraying/damage to the cable such as a significant decrease in cable diameter.
- b) Frame damage/deformation.
- c) Proper functioning of the carriage latch mechanism. See [TRANSPORTING THE A-LIFT](#) on p. 11.
- d) Unusual noise, binding or rough movement of the carriage when the winch handle is rotated;

At least every 2 weeks, inspect the following:

1. [Refer to [RAISING AND LOWERING THE DECK](#) on p. 8] Winch, winch mounting bracket, cable, and pulley: Cycle the carriage up and down. Listen for unusual noises and watch for binding or rough movement as the deck moves. If the carriage does not move smoothly or is noisy as it moves up or down, apply silicon wax or spray to the inside of the mast frame. Examine the winch. Make sure that the spool is intact and rotates smoothly when the handle is turned. Inspect the mounting bracket. The winch should be solidly attached to the bracket. Tighten loose fasteners. Lower the deck and examine the cable for reeving, stretching, thinning portions, etc. Confirm that pulleys are securely fastened to the mast & rotate freely.
2. Frame (mast, base, deck, deck rollers, forks, tank lifting mechanism (A-LIFT-HTL)): examine all frame members for damaged welds, severe rusting, cracks, bends, etc. Remove rust with steel wool. Clean the affected areas and apply touch-up paint to them.
3. Casters and wheels: check each caster and wheel for wobbling, damage, and severe wear. Wheels and casters should roll smoothly. Clean the casters to remove grit from the surfaces, if necessary.
4. Hardware: examine the pins, bolts, nuts, etc. Tighten loose fasteners.
5. Floor lock: if your unit is equipped with the floor lock option confirm that it makes solid contact with the ground when applied. Check the condition of the rubber pad. Replace the pad if wear or damage affects its function.

### MAINTENANCE

Implement a maintenance program to ensure that the lifter functions properly. ANSI/ITSDF standard B56.10, “Manually propelled high lift industrial trucks”, Part 2 includes *Maintenance and Rebuild Practices*. A copy of the current revision of the B56.10 standard is downloadable for free from the ITSDF website (see [www.itsdf.org](http://www.itsdf.org)). Apply the *Maintenance* procedures from the Standard in conjunction with the following:

1. Tag the lifter, “Out of Service” and perform an *INSPECTION* as described above. If deformity, corrosion, rusting, or excessive wear of structural members is present, remove the lifter from service.
3. Remove dirt or other matter from the cable and pulleys and other lifter surfaces.
4. Perform all other necessary adjustments and/or repairs. DO NOT modify the lifter.
5. Make a dated record of the repairs, adjustments and/or replacements made.

## LABELING DIAGRAM

Each unit should be labeled as shown in the diagram. However, label content and locations are subject to change so your product might not be labeled exactly as shown. Compare the diagram below to your [RECORD OF SATISFACTORY CONDITION](#). If there are any differences between actual labeling and this diagram, adapt the diagram to reflect actual labeling. Replace all labels that are damaged, missing, or not easily readable (e.g. faded). To order replacement labels or to inquire whether your unit is properly labeled, contact the technical service and parts department online at <https://www.vestil.com/page-parts-request.php> or by calling (260) 665-7586 and asking for the Parts Department.



## LIMITED WARRANTY

Vestil Manufacturing Company ("Vestil") warrants this product to be free of defects in material and workmanship during the warranty period. Our warranty obligation is to provide a replacement for a defective, original part covered by the warranty after we receive a proper request from the Warrantee (you) for warranty service.

### Who may request service?

Only a warrantee may request service. You are a warrantee if you purchased the product from Vestil or from an authorized distributor AND Vestil has been fully paid.

### Definition of "original part"?

An original part is a part used to make the product as shipped to the Warrantee.

### What is a "proper request"?

A request for warranty service is proper if Vestil receives: 1) a photocopy of the [Customer Invoice](#) that displays the shipping date; AND 2) a [written request](#) for warranty service including your name and phone number. Send requests by one of the following methods:

<p><u>US Mail</u> Vestil Manufacturing Company 2999 North Wayne Street, PO Box 507 Angola, IN 46703</p>	<p><u>Fax</u> (260) 665-1339 <u>Phone</u> (260) 665-7586</p>	<p><u>Email</u> <a href="mailto:info@vestil.com">info@vestil.com</a> Enter "Warranty service request" in subject field.</p>
---	--	---

In the written request, list the parts believed to be defective and include the address where replacements should be delivered. After Vestil receives your request for warranty service, an authorized representative will contact you to determine whether your claim is covered by the warranty. Before providing warranty service, Vestil will require you to send the entire product, or just the defective part (or parts), to its facility in Angola, IN.

### What is covered under the warranty?

The warranty covers defects in the following original, dynamic parts: motors, hydraulic pumps, motor controllers, and cylinders. It also covers defects in original parts that wear under normal usage conditions ("wearing parts"), such as bearings, hoses, wheels, seals, brushes, and batteries.

### How long is the warranty period?

The warranty period for original dynamic components is 90 days. For wearing parts, the warranty period is 90 days. Both warranty periods begin on the date Vestil ships the product to the Warrantee. If the product was purchased from an authorized distributor, the periods begin when the distributor ships the product. Vestil may, at its sole discretion, extend a warranty period for products shipped from authorized distributors by up to 30 days to account for shipping time.

### If a defective part is covered by the warranty, what will Vestil do to correct the problem?

Vestil will provide an appropriate replacement for any covered part. An authorized representative of Vestil will contact you to discuss your claim.

### What is not covered by the warranty?

The Warrantee (you) is responsible for paying labor costs and freight costs to return the product to Vestil for warranty service.

### Events that automatically void this Limited Warranty.

- Misuse;
- Negligent assembly, installation, operation or repair;
- Installation/use in corrosive environments;
- Inadequate or improper maintenance;
- Damage sustained during shipping;
- Collisions or other accidents that damage the product;
- Unauthorized modifications: Do not modify the product IN ANY WAY without first receiving written authorization from Vestil.

### Do any other warranties apply to the product?

Vestil Manufacturing Co. makes no other express warranties. All implied warranties are disclaimed to the extent allowed by law. Any implied warranty not disclaimed is limited in scope to the terms of this Limited Warranty. Vestil makes no warranty or representation that this product complies with any state or local design, performance, or safety code or standard. Noncompliance with any such code or standard is not a defect in material or workmanship.

