

DESCRIPTION

Stainless steel mop basin, type 304, 16 gauge, 610 x 610 x 254/406 mm (24 x 24 x 10 /16 in), #4 finish internal surfaces, rim and backsplash panel, against the wall installation, full skirt on 3 sides, 152 mm (6 in) high integrated backsplash, center drain, presloped, interior square corners, 38 mm (1 1/2 in) flattened rim. DN 76 mm (3 in) stainless steel dome strainer/lint basket with locking nut, neoprene gasket for push-on connections.

Meets standards : ASME A 112.19.3 / CSA 845.4-08 (R2013)

Stainless steel dome strainer/lint basket with locking nut, neoprene gasket for push-on connections for DN 3".

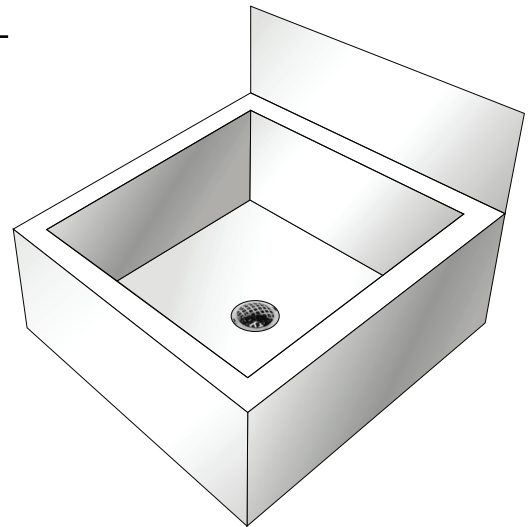

OPTIONS

- 

Suffixe -C :
2 Panels and skirt for corner installation.
- 

Suffixe -PM3 :
Wall and skirt panels on all 3 sides
- 

Suffixe -PMEXT :
Extended Wall panel (max. 36").
- 

Suffixe -316 :
Type 316 (for installation in corrosive locations)

