

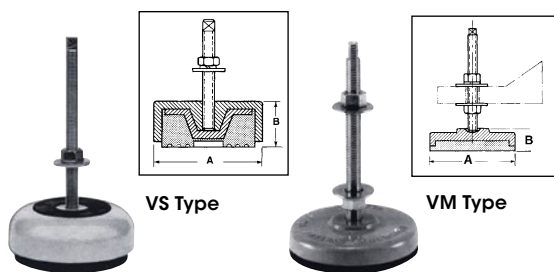

Leveling Mounts

Self aligning leveling mounts compensate for uneven floors or mounting deflection. Made from oil resistant non-skid, ribbed neoprene rubber. VS series are used where maximum dampening of shock is required or to prevent creeping and walking of workshop machines.



Model No.	Type	Maximum Load in lbs.		Leveling Adjustment"	Leveling Bolt Sizes"		Mount Dimensions		Price /Each
		Non-Impact Machinery	Impact		A"	B"			
UD172	VM	500	350	1.0	1/2NC x 6	4.0	1		
TP197	VM	1000	700	1.0	1/2NC x 6	4.0	1		
UA279	VM	2000	1400	1.0	5/8NC x 8	4.0	1		
UA278	VM	2000	1400	1.0	3/4NF x 6	7.0	1 1/4		
UA277	VM	4000	2800	1.0	3/4NF x 6	7.0	1 1/4		
UA276	VM	8000	5600	1.0	3/4NF x 6	7.0	1 1/4		
UA297	VM	12,000	8500	1.0	1NS x 8	7.0	1 1/4		
UD170	NVS	1500	1000	1/2	1/2NC x 6	3.5	1 1/2		
UD171	NVS	4500	3000	1/2	5/8NC x 8	5.5	2		
UA290	NVS	15,000	7,000	1/2	1NS x 8	9	2 1/4		
UA289	NVS	15,000	17,000	1/2	1NS x 8	9	2 1/4		

Vibra-Wedge Isolators

- Designed for the installation and precision levelling of heavy industrial machinery
- 3 machined wedges are mounted and held together by a horizontal adjusting bolt
- A lock screw secures the mount in the levelled position
- A special opening allows for bolting of the machine to the floor

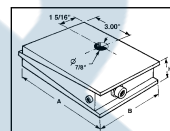

Note: Max. levelling is 1/4" (6 mm). If more height is required use a shim plate.

Model No.	A (mm)	B (mm)	H (mm)	Max. Load lbs.	Price /Each
UP587	150	100	40+/-5	15000	
UP588*	150	100	50+/-5	9000	

*Neoprene top and bottom included.

Neoprene Vibration Pads

Install machinery and equipment on double sided moulded neoprene pads to isolate vibration, shock and reduce noise level. Waffle design allows material expansion without losing stability. Pads should be cut to the size of machines feet allowing 1/2" margin on all sides. Pads resist oil and solvents.

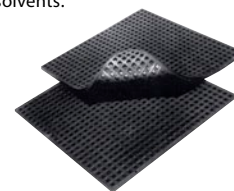

Model No.	Load Range	Size"	Price /Each
UA295	1-25 PSI	18 x 18 x 5/16	
UA291	10-50 PSI	18 x 18 x 5/16	
UA270	40-100 PSI	18 x 18 x 5/16	
UD168	75-200 PSI	18 x 18 x 1/2	
UA292	150-300 PSI	18 x 18 x 1/2	
UA273	1-25 PSI	6 x 6 x 5/16	
UA271	10-50 PSI	6 x 6 x 5/16	
UA275	40-100 PSI	6 x 6 x 5/16	
UA274	75-200 PSI	6 x 6 x 1/2	
UA296	150-300 PSI	6 x 6 x 1/2	

Anti-Vibration Cupmounts

Industrial cupmounts provide excellent protection against severe impact shock, vibration and noise

- High vibration dampening characteristics
- Fail-safe, rugged interlocking metal and neoprene construction provides exceptional performance against shear and compression forces and flexible vertically and stable horizontally
- Metal cupmount component is cold-rolled steel coupled with an elastomer-in-compression design
- High-grade neoprene elastomer provides resistance to oil and ozone
- Each side flange has through holes allowing for effective attachment to supporting equipment structure

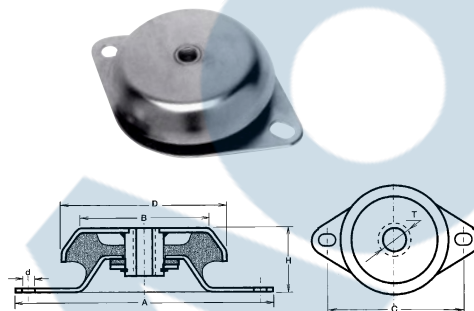

Model No.	Maximum load in lbs.		Mount Dimensions					Price /Each	
	Non-impact Machinery	Impact	A"	B"	C"	D"	H"		T"
UD185	400	250	6	2 3/4	5	3 5/8	1 3/8	0.390	1/2 - 13
UD186	700	450	6	2 3/4	5	3 5/8	1 3/8	0.390	1/2 - 13
UD187	1400	900	7 11/16	4	6 3/8	5 3/16	1 11/16	0.550	5/8 - 11
UD188	2600	1700	7 11/16	4	6 3/8	5 3/16	1 11/16	0.550	5/8 - 11

Cylindrical Vibration Isolators

- Natural rubber isolators can be used on all industrial motors, compressors, fans and machinery
- Not suitable for wall or ceiling mounting applications or with use in oil or solvent soaked environments

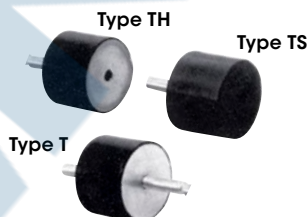

Model No.	Type	Dimensions (mm)				Load Cap. lbs.	Price /Each
		A	B	C	D		
UA280	T	20	15	M-6	13	55	
UD167	T	20	25	M-6	13	50	
UA283	T	30	30	M-8	20	175	
UA284	T	35	35	M-8	20	195	
UA286	T	40	40	M-8	25	260	
UA240	TH	40	40	M-10	25	330	
UA287	TH	20	15	M-6	13	55	
UA293	TH	25	25	M-8	20	85	
UA294	TH	30	30	M-8	20	175	
UA298	TS	20	15	M-6	13	55	
UA299	TS	25	25	M-8	20	85	
UA288	TS	30	30	M-8	20	175	

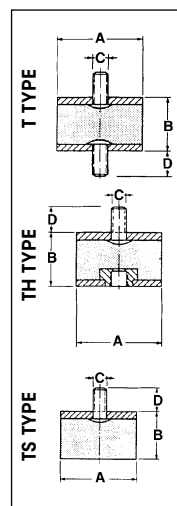

Did you find what you were looking for?



Contact us. We can help.